

RA_g_Gastranaerophilales

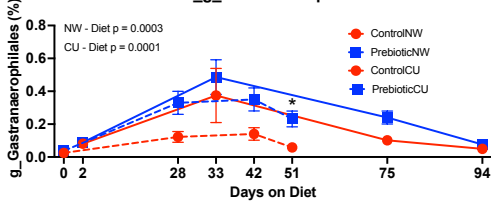

RA_g_NK4A214_group

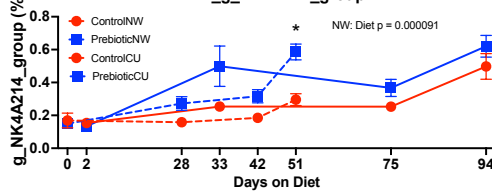

RA_g_Erysipelotclostridiaceae

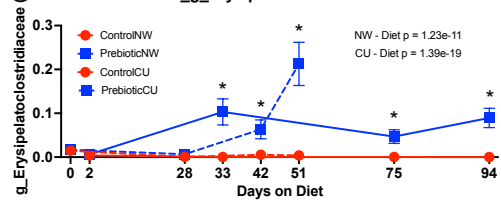

RA_g_Lachnospiraceae_UCG-009

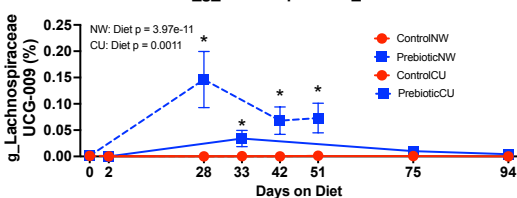

RA_g_Marvinbryantia

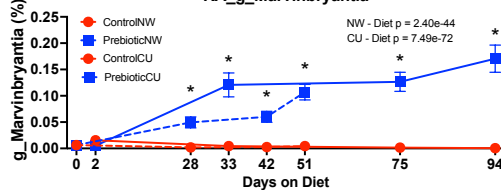

RA_g_Paludicola

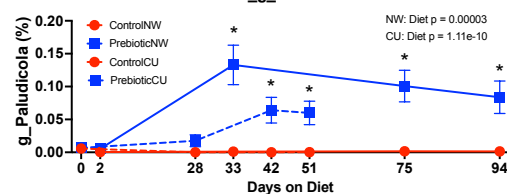

RA_g_UCG-010

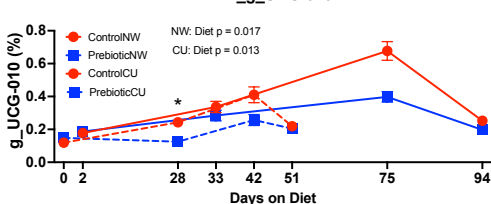

RA_g_Acetatifactor

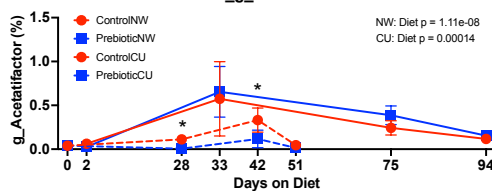

RA_g_ASF356

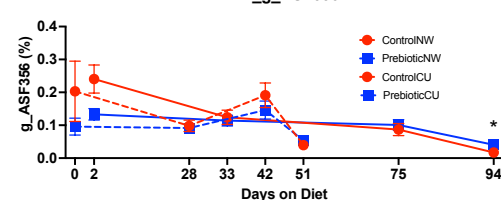

RA_g_Tuzzerella

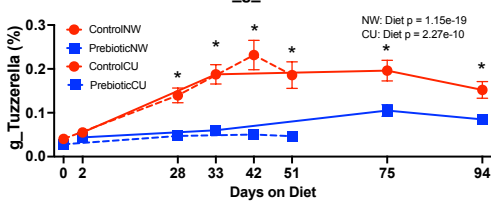

RA_g_UCG-009

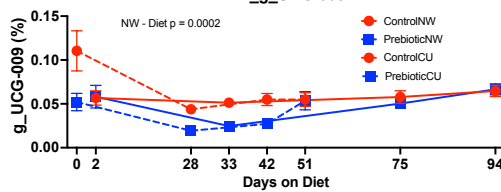

RA_g_Butyricicoccus

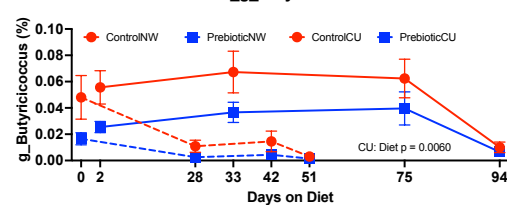

RA_g_[Clostridium]_methylpentosum_group

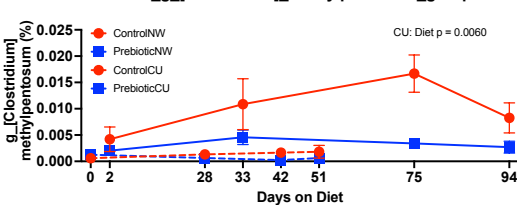

RA_g_Oscillibacter

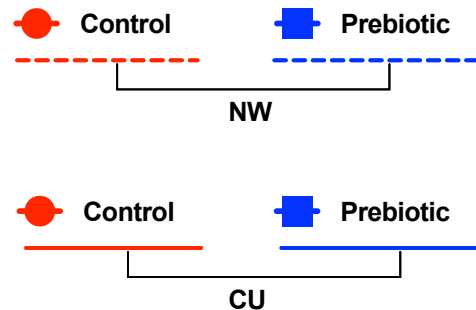
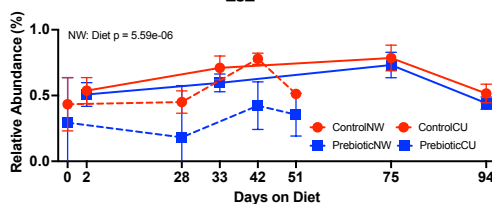

Nonparametric longitudinal data (nparLD) Table: ANOVA-type statistic (ATS)

Genera (relative abundances)

| | | Diet - F-value; p-value | | Weeks - F-value; p-value | | Diet x Time | |
|---|----|-------------------------|---------------------|-----------------------------|----------------------|----------------------------|---------------------|
| Higher in Prebiotic Diet - color indicates consistent effect across study site | | | | | | | |
| Ultra Low Relative Abundance (<1%) | | | | | | | |
| Gastranaerophilales (Supp Fig 1) | NW | $F_{(1,2.70)} = 13.06$ | p = 0.0003 | $F_{(2.70,57.73)} = 25.86$ | p = 2.70e-15 | $F_{(2.70,57.73)} = 2.71$ | p = 0.049 |
| | CU | $F_{(1,2.75)} = 5.013$ | p = 0.00010 | $F_{(2.75,69.41)} = 27.58$ | p = 1.53e-16 | $F_{(2.75,69.41)} = 0.853$ | p = 0.456 |
| NK4A214_group (Supp Fig 1) | NW | $F_{(1,2.55)} = 15.31$ | p = 0.000091 | $F_{(2.55,59.93)} = 30.74$ | p = 2.76e-17 | $F_{(2.55,59.93)} = 3.02$ | p = 0.036 |
| | CU | $F_{(1,2.81)} = 3.43$ | p = 0.0639 | $F_{(2.81,67.78)} = 124.83$ | p = 7.018e-27 | $F_{(2.81,67.78)} = 1.14$ | p = 0.329 |
| Erysipelatoclostridiaceae (Supp Fig 1) | NW | $F_{(1,2.37)} = 45.92$ | p = 1.23e-11 | $F_{(2.37,55.35)} = 17.36$ | p = 2.20e-09 | $F_{(2.37,55.35)} = 32.68$ | p = 3.20e-17 |
| | CU | $F_{(1,2.71)} = 81.95$ | p = 1.39e-19 | $F_{(2.71,43.39)} = 5.58$ | p = 0.0026 | $F_{(2.71,43.39)} = 13.11$ | p = 6.25e-08 |
| Lachnospiraceae_UCG-009 (Supp Fig 1) | NW | $F_{(1,2.44)} = 43.63$ | p = 3.97e-11 | $F_{(2.44,33.98)} = 8.06$ | p = 0.00009 | $F_{(2.44,33.98)} = 12.15$ | p = 7.17e-07 |
| | CU | $F_{(1,2.72)} = 10.60$ | p = 0.0011 | $F_{(2.72,41.14)} = 5.64$ | p = 0.0011 | $F_{(2.72,41.14)} = 4.02$ | p = 0.009 |
| Marvinbryantia (Supp Fig 1) | NW | $F_{(1,2.80)} = 195.14$ | p = 2.40e-44 | $F_{(2.80,59.99)} = 12.20$ | p = 1.37e-07 | $F_{(2.80,59.99)} = 25.80$ | p = 9.81e-16 |
| | CU | $F_{(1,2.38)} = 321.32$ | p = 7.49e-72 | $F_{(2.38,68.96)} = 23.14$ | p = 2.33e-12 | $F_{(2.38,68.96)} = 49.31$ | p = 8.28e-26 |
| Paludicola (Supp Fig 1) | NW | $F_{(1,2.03)} = 17.39$ | p = 0.00003 | $F_{(2.03,38.77)} = 5.20$ | p = .00526 | $F_{(2.03,38.77)} = 6.84$ | p = 0.001 |
| | CU | $F_{(1,2.77)} = 41.62$ | p = 1.11e-10 | $F_{(2.77,42.42)} = 15.33$ | p = 2.18e-09 | $F_{(2.77,42.42)} = 7.99$ | p = 0.000045 |

Higher in Control Diet - color indicates consistent effect across study site

| | | Diet - F-value; p-value | | Weeks - F-value; p-value | | Diet x Time | |
|--|----|-------------------------|---------------------|-----------------------------|---------------------|----------------------------|---------------------|
| Ultra Low Relative Abundance (<1%) | | | | | | | |
| UCG-010 (Supp Fig 1) | NW | $F_{(1,2.94)} = 5.67$ | p = 0.017 | $F_{(2.94,59.52)} = 13.72$ | p = 8.14e-09 | $F_{(2.94,59.52)} = 4.98$ | p = 0.020 |
| | CU | $F_{(1,2.81)} = 6.17$ | p = 0.013 | $F_{(2.81,70.55)} = 45.90$ | p = 5.71e-28 | $F_{(2.81,70.55)} = 1.75$ | p = 0.158 |
| Acetatifactor (Supp Fig 1) | NW | $F_{(1,2.91)} = 32.64$ | p = 1.11e-08 | $F_{(2.91,59.04)} = 4.15$ | p = 0.0065 | $F_{(2.91,59.04)} = 7.67$ | p = 0.000049 |
| | CU | $F_{(1,2.94)} = 14.47$ | p = 0.00014 | $F_{(2.94,71.92)} = 9.48$ | p = 3.54e-06 | $F_{(2.94,71.92)} = 0.71$ | p = 0.55 |
| ASF356 (Supp Fig 1) | NW | $F_{(1,2.88)} = 0.31$ | p = 0.577 | $F_{(2.88,59.31)} = 11.95$ | p = 1.39e-07 | $F_{(2.88,59.31)} = 0.495$ | p = 0.677 |
| | CU | $F_{(1,2.71)} = 0.926$ | p = 0.336 | $F_{(2.71,71.52)} = 37.74$ | p = 2.86e-22 | $F_{(2.71,71.52)} = 3.07$ | p = 0.031 |
| Tuzzerella (Supp Fig 1) | NW | $F_{(1,2.87)} = 82.34$ | p = 1.15e-19 | $F_{(2.87,57.95)} = 17.95$ | p = 3.05e-11 | $F_{(2.87,57.95)} = 7.55$ | p = 0.00006 |
| | CU | $F_{(1,2.68)} = 40.22$ | p = 2.27e-10 | $F_{(2.68,71.35)} = 22.45$ | p = 2.99e-13 | $F_{(2.68,71.35)} = 3.54$ | p = 0.018 |
| UCG-009 (Supp Fig 1) | NW | $F_{(1,2.79)} = 18.41$ | p = 0.00002 | $F_{(2.79,59.46)} = 4.34$ | p = 0.0057 | $F_{(2.79,59.46)} = 1.80$ | p = 0.150 |
| | CU | $F_{(1,2.63)} = 3.73$ | p = 0.053 | $F_{(2.63,71.39)} = 7.66$ | p = 9.92e-05 | $F_{(2.63,71.39)} = 2.45$ | p = 0.070 |
| Butyricococcus (Sup Fig 1) | NW | $F_{(1,2.42)} = 3.56$ | p = 0.059 | $F_{(2.42,58.33)} = 14.94$ | p = 2.80e-08 | $F_{(2.42,58.33)} = 0.768$ | p = 0.486 |
| | CU | $F_{(1,2.58)} = 3.95$ | p = 0.047 | $F_{(2.58,68.25)} = 129.02$ | p = 8.77e-28 | $F_{(2.58,68.25)} = 1.88$ | p = 0.654 |
| Clostridium_methylpentosum_group (Sup Fig 1) | NW | $F_{(1,2.83)} = 2.50$ | p = 0.114 | $F_{(2.83,50.64)} = 0.206$ | p = 0.882 | $F_{(2.83,50.64)} = 1.01$ | p = 0.383 |
| | CU | $F_{(1,2.72)} = 7.55$ | p = 0.0060 | $F_{(2.72,65.57)} = 5.00$ | p = 0.0027 | $F_{(2.72,65.57)} = 1.50$ | p = 0.215 |
| Oscillibacter (Supp Fig 1) | NW | $F_{(1,2.67)} = 20.63$ | p = 5.59e-06 | $F_{(2.67,59.96)} = 5.38$ | p = 0.0017 | $F_{(2.67,59.96)} = 1.58$ | p = 0.197 |
| | CU | $F_{(1,2.81)} = 0.520$ | p = 0.471 | $F_{(2.81,70.71)} = 7.55$ | p = 0.000076 | $F_{(2.81,70.71)} = 0.12$ | p = 0.938 |

RA_g_Muribaculaceae

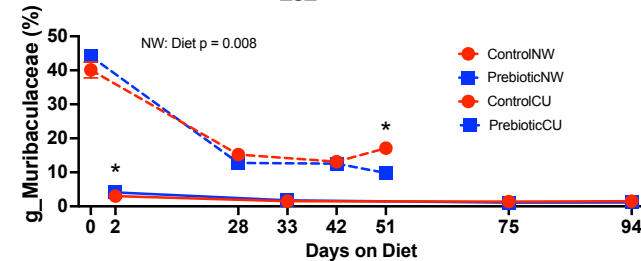

RA_g_Blautia

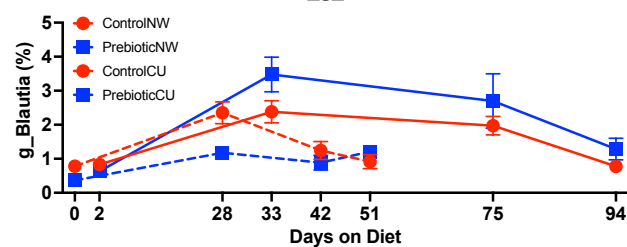

RA_g_RF39

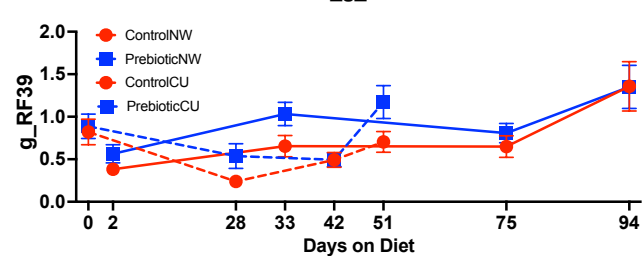

RA_g_Lachnoclostridium

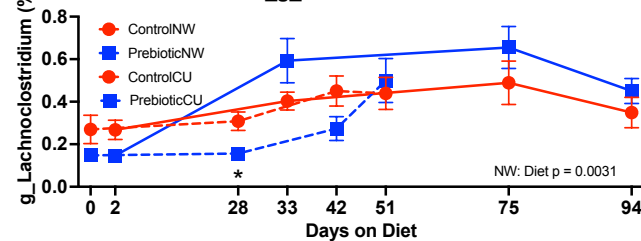

RA_g_A2

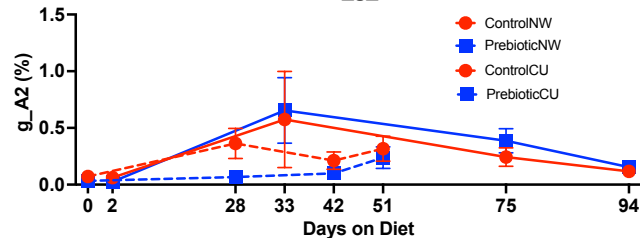

RA_g_Alistipes

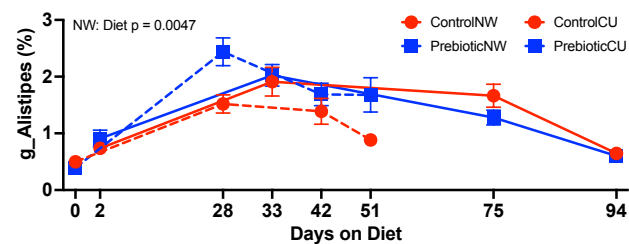

Nonparametric longitudinal data (nparLD) Table: ANOVA-type statistic (ATS)

| Genera (relative abundances) | Diet - F-value; p-value | | Weeks - F-value; p-value | | Diet x Time | | |
|-------------------------------|-------------------------|------------------------|--------------------------|-----------------------------|----------------------|-----------------------------|---------------------|
| | Inconsistent Effects | | | | | | |
| Muribaculaceae (Sup Fig 2) | NW | $F_{(1,2.74)} = 7.06$ | p = 0.008 | $F_{(2.74,51.30)} = 118.13$ | p = 3.33e-70 | $F_{(2.74,51.30)} = 9.90$ | p = 0.000004 |
| | CU | $F_{(1,2.79)} = 0.004$ | p = 0.946 | $F_{(2.79,68.50)} = 92.744$ | p = 4.74e-56 | $F_{(2.79,68.50)} = 7.006$ | p = 0.00016 |
| Blautia (Sup Fig 2) | NW | $F_{(1,2.94)} = 1.05$ | p = 0.305 | $F_{(2.94,51.13)} = 16.22$ | p = 2.20e-10 | $F_{(2.94,51.13)} = 5.22$ | p = 0.0014 |
| | CU | $F_{(1,2.52)} = 1.45$ | p = 0.239 | $F_{(2.52,71.81)} = 39.76$ | p = 5.08e-22 | $F_{(2.52,71.81)} = 1.89$ | p = 0.140 |
| RF39 (Sup Fig 2) | NW | $F_{(1,2.68)} = 0.73$ | p = 0.39 | $F_{(2.68,59.24)} = 19.52$ | p = 1.48e-11 | $F_{(2.68,59.24)} = 0.890$ | p = 0.436 |
| | CU | $F_{(1,2.82)} = 3.56$ | p = 0.059 | $F_{(2.82,71.85)} = 9.24$ | p = 7.22e-06 | $F_{(2.82,71.85)} = 0.919$ | p = 0.426 |
| Lachnoclostridium (Sup Fig 2) | NW | $F_{(1,2.92)} = 8.72$ | p = 0.0031 | $F_{(2.92,59.56)} = 10.40$ | p = 1.04e-06 | $F_{(2.92,59.56)} = 2.79$ | p = 0.040 |
| | CU | $F_{(1,2.85)} = 1.94$ | p = 0.164 | $F_{(2.85,79.69)} = 21.00$ | p = 4.80e-13 | $F_{(2.85,79.69)} = 7.68$ | p = 0.000057 |
| A2 (Sup Fig 2) | NW | $F_{(1,2.92)} = 3.53$ | p = 0.060 | $F_{(2.92,59.76)} = 4.69$ | p = 0.0031 | $F_{(2.92,59.76)} = 0.622$ | p = 0.596 |
| | CU | $F_{(1,2.88)} = 2.79$ | p = 0.095 | $F_{(2.88,69.91)} = 14.68$ | p = 2.883e-09 | $F_{(2.88,69.91)} = 2.15$ | p = 0.095 |
| Alistipes (Sup Fig 2) | NW | $F_{(1,2.82)} = 7.99$ | p = 0.0047 | $F_{(2.82,58.41)} = 41.33$ | p = 8.21e-30 | $F_{(2.82,58.41)} = 2.04$ | p = 0.190 |
| | CU | $F_{(1,2.77)} = 0.322$ | p = 0.57 | $F_{(2.77,71.937)} = 42.86$ | p = 9.04e-26 | $F_{(2.77,71.937)} = 1.267$ | p = 0.284 |